

Model
1999 Legend

Applicable To
VIN
**JHMKA9...XC200115
thru 201135 and
JHMKA...XC400010
thru 400165**

File Under



Bulletin No.
99-546

Issue Date
November 1999

1999 Legend: Seat Belt Buckle Replacement on Driver Seat

BACKGROUND

On affected vehicles, a faulty seat belt buckle switch on the driver seat may cause the SRS indicator to come on and the system to store DTC 9-3 (faulty driver's seat belt buckle switch).

CORRECTIVE ACTION

Replace the seat belt buckle on the driver seat and, if necessary, erase the SRS DTC with the PGM Tester.

PARTS INFORMATION

Driver Seat Belt Buckle (left-hand-drive vehicles):

Graphite Black: P/N 04816-SZ3-305ZA
Quartz Gray: P/N 04816-SZ3-305ZB
Mild Beige: P/N 04816-SZ3-305ZC

Driver Seat Belt Buckle (right-hand-drive vehicles):

Graphite Black: P/N 81455-SZ3-305ZA
Quartz Gray: P/N 81455-SZ3-305ZB
Mild Beige: P/N 81455-SZ3-305ZC

REQUIRED SPECIAL TOOLS

PGM Tester with SN902 or more recent software

REQUIRED MATERIALS

4" Wire Ties (2 needed), commercially available

WARRANTY CLAIM INFORMATION

The normal warranty applies.

Flat rate time: 0.7 hour

Failed part: Left-hand drive
P/N 81855-SZ3-305ZA
Right-hand drive
P/N 81455-SZ3-305ZA

Defect code: 540

REPAIR PROCEDURE

NOTE: Do not scratch or damage interior parts during this procedure.

1. Make sure you have the anti-theft code for the radio, then write down the radio station presets.
2. Disconnect the negative battery terminal, then wait at least three minutes before you continue.
3. Wrap the end of a flat-tip screwdriver with tape, then carefully pry off the end covers from the seat tracks on the driver seat.

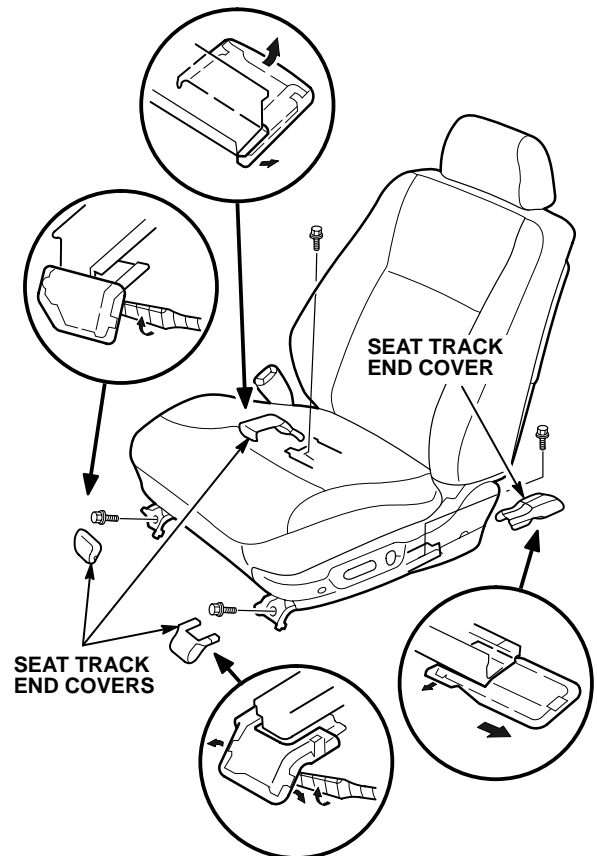

4. Remove the seat track bolts (4).

5. Tilt back the seat, and disconnect the connectors on the underside.

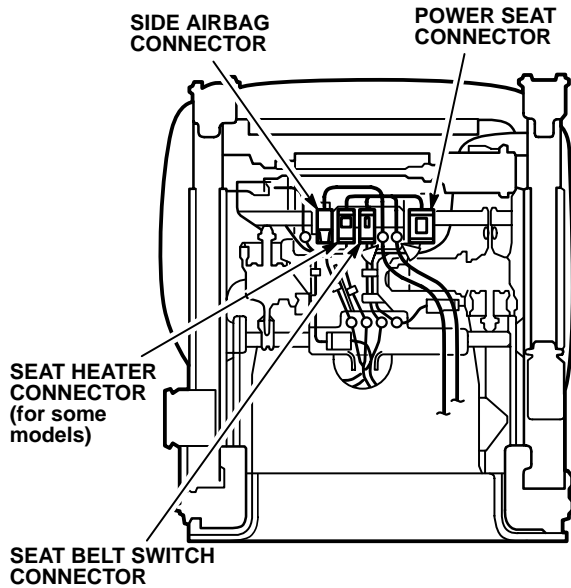

6. Remove the headrest.
7. Carefully remove the seat through the door opening.
8. Remove the seat belt switch harness from the seat cushion (2 wire ties, 2 clips, and 2 hooks).

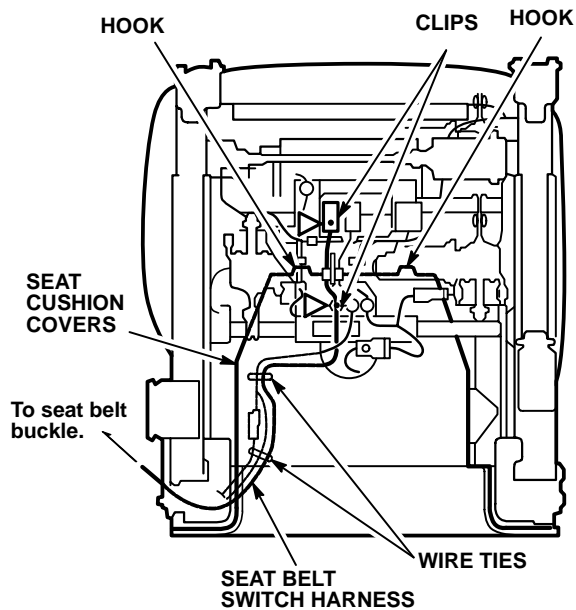

9. Remove the center cover from the seat (2 screws and one clip).

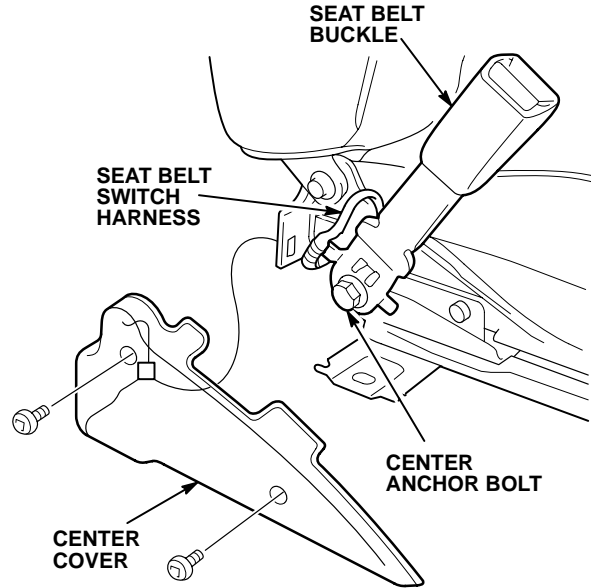

10. Remove the center anchor bolt with a 14 mm wrench, then remove the seat belt buckle.
11. Install a new seat belt buckle with the old anchor bolt, bushing, wave washer, and toothed lock washer. Torque the bolt to 32 N·m (24 lb-ft).

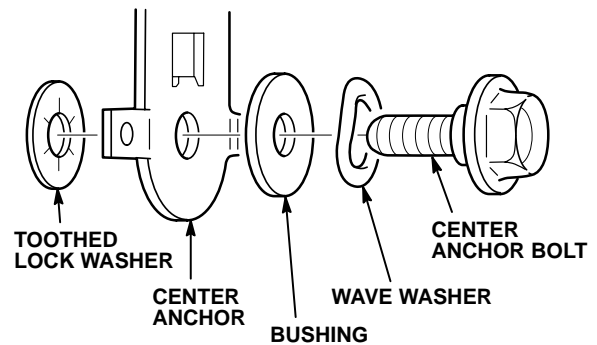

12. Route the seat belt switch harness along the underside of the seat, and attach its two clips and hooks to the seat cushion.

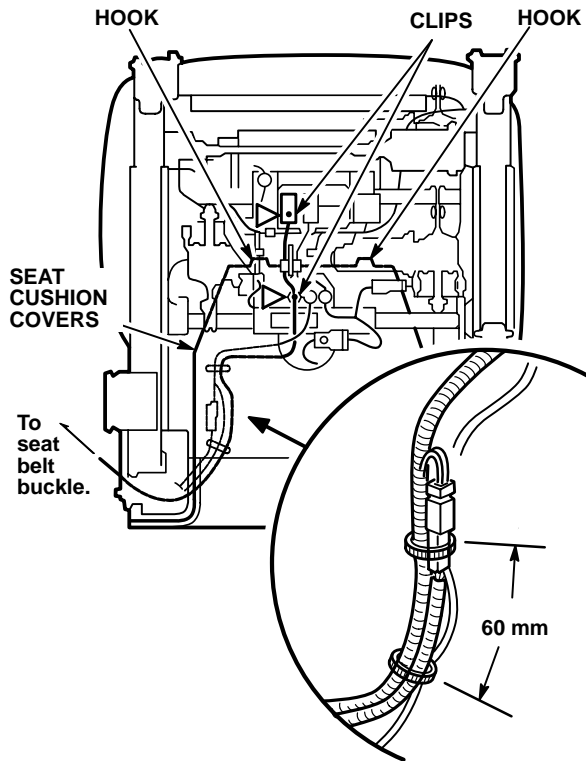

13. Install two new wire ties 60 mm apart as shown, and trim any excess.
14. Install the center cover on the seat, and carefully place the seat in the vehicle.
15. Reconnect the connectors on the underside of the seat. (These are the same ones you disconnected in step 5.)
16. Install the seat track bolts, and torque them to 39 N·m (29 lb-ft).
17. Install the seat track end covers and the headrest.
18. Connect the negative battery terminal, and set the clock.
19. Enter the radio station presets.
20. If the SRS indicator light was on (see **BACKGROUND**), erase the SRS DTC with the PGM Tester.