



1999 Legend PDI Information

Most of the features, equipment, and delivery preparation procedures for the 1999 Legend are the same as for previous models. This service bulletin describes those things that are unique to the 1999 model.

FLOATING CENTER PAD HORN SWITCH

In place of the horn buttons used on the previous Legend steering wheels; the '99 model uses the entire center of the steering wheel as the horn switch. This change is done by floating the airbag in the steering wheel.

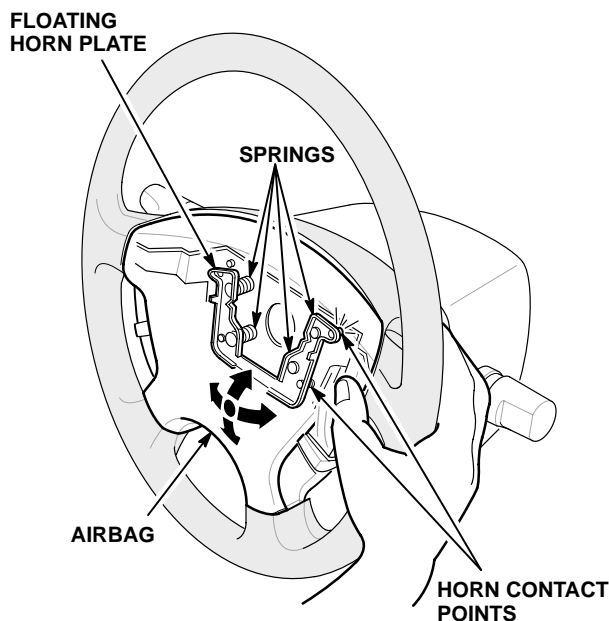

LARGER BRAKES

The 1999 Legend has 300 mm front brake discs; they are 18 mm larger than those on the 1996–98 Legend. Earlier Legend wheels, including the optional steel wheels used for snow tires, do not fit on the '99 model.

SIDE AIRBAGS

Side airbags are located in the outer bolsters of the front seats. The front passenger's side airbag system includes an Occupant Position Detection System (OPDS). This system consists of sensors and a

control unit located in the front passenger's seat-back. The control unit sends occupant height and position information to the SRS unit.

If the SRS unit determines that the front passenger's head is in the deployment path of the side airbag, it automatically disables the airbag. When the side airbag is disabled, the Side Airbag indicator light in the gauge assembly comes on to alert the driver that the passenger's side airbag will not deploy in a side impact.

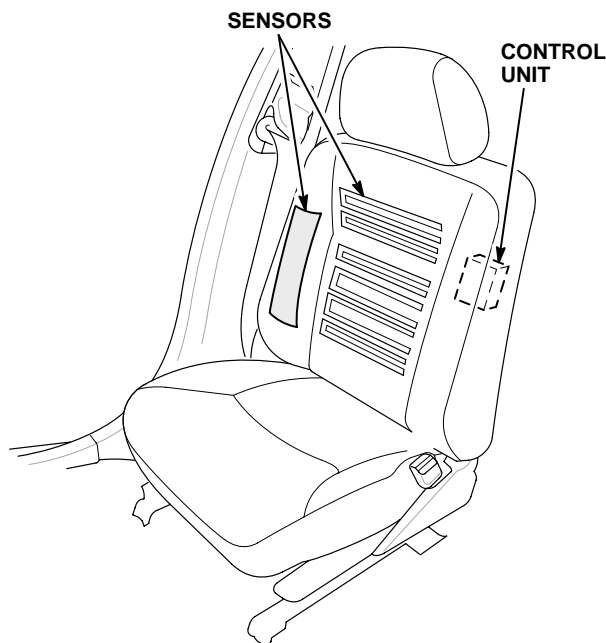
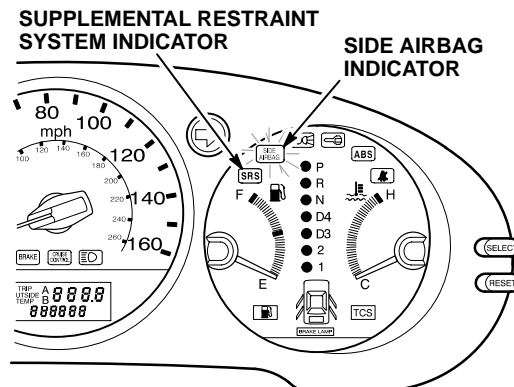

When the OPDS detects that the passenger's head is in the path of deployment for more than three seconds, the side airbag light comes on. The light stays on for three seconds longer than the sensor detects the blocked path.

The side airbags in both seats deploy through the bolster seam. The cover is sewn with a special stitching method that allows reliable deployment. You must replace the seat covers with the correct part. Do not make repairs to the seat cover; instead, replace the seat cover as a unit.

READING SRS DTCs

Additional SRS codes have been added for the side airbag system, and the SRS light indicates these codes differently. For example, the "10" in codes 11 through 14 is indicated by four short blinks. Refer to the 1999 Legend Shop Manual Supplement for more information.

Example:

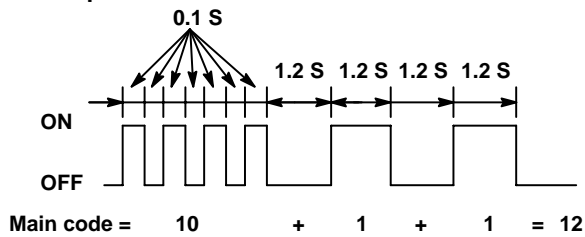

HEATED SEATS

The front passenger's seat-back does not have a heating element.

HIGH INTENSITY DISCHARGE (HID) HEADLIGHTS

The new low-beam headlight is a discharge type. It uses high voltage at start-up, and it requires special attention during servicing. Do not check the bulb operation outside of the headlight assembly.

HOOD

The redesigned hood must be removed before the engine can be removed.

FRONT SPOILER AND REAR SPLASH GUARDS

The front spoiler and rear splash guards are not installed at the factory. They must be installed during PDI.

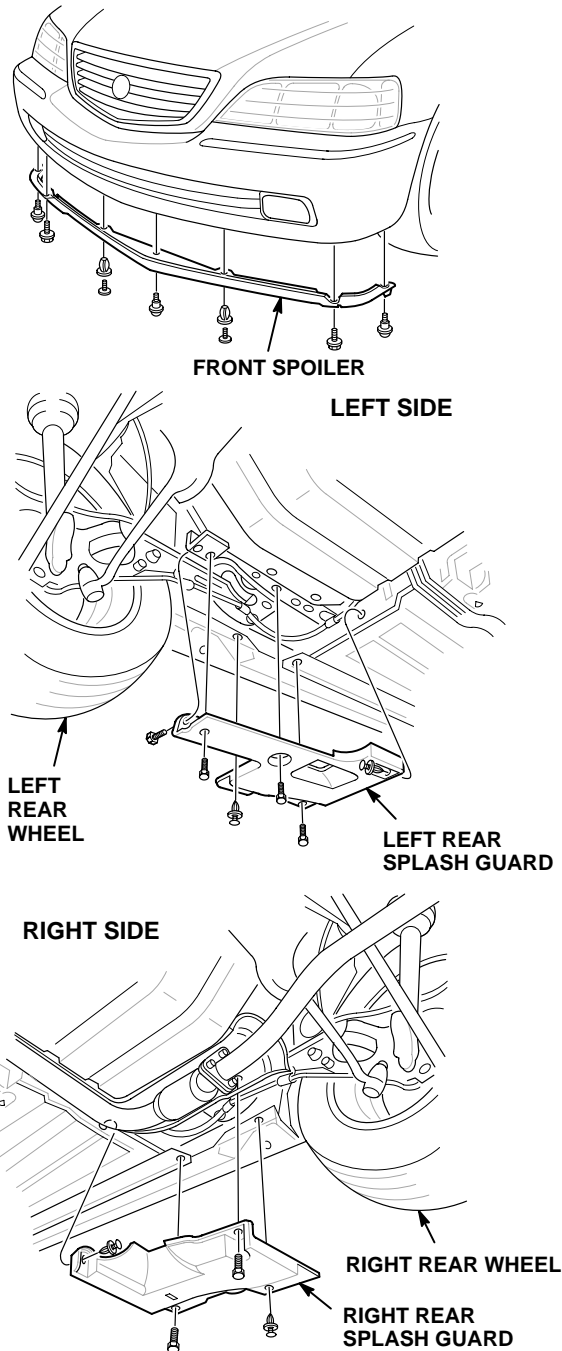

WARRANTY CLAIM INFORMATION

None; these procedures are considered part of PDI.