



Applies To: **1996-00 Civic** – ALL
1997-01 CR-V – ALL
1998-02 Accord – ALL

December 2003

Brake System Indicator Comes On and Goes Off

SYMPTOM

The brake system indicator comes on after a cold start and then goes off after a few minutes of driving.

PROBABLE CAUSE

The master cylinder reservoir filter is not allowing the cap to vent properly, causing the fluid level in the filter to change.

CORRECTIVE ACTION

Replace the master cylinder reservoir filter.

PARTS INFORMATION

Master Cylinder Reservoir Filter: P/N 46666-S04-J02

Float: P/N 46662-S84-999

WARRANTY CLAIM INFORMATION

In warranty: The normal warranty applies.

Operation Number: 413133

Flat Rate Time: 0.4 hour

Failed Part: P/N 46666-S04-J02

Defect Code: 05401

Symptom Code: 03205

DIAGNOSIS

1. Make sure the brake master cylinder fluid level is at its proper level.
2. Release the parking brake.
3. Check the movement of the float in the reservoir:
 - If the float moves up and down freely, go to step 4.
 - If the float does not move freely, replace the cap and recheck the symptom.
4. Check that the float does float in brake fluid:
 - If it floats, go to step 5.
 - If it sinks, replace the float with a new part, and recheck the symptom.

5. Check for continuity between the terminals of the cap. You should find no continuity when the float is up, and you should find continuity when the float is down.
 - If continuity is correct, go to REPAIR PROCEDURE.
 - If continuity is not correct, replace the cap and recheck the symptom.

REPAIR PROCEDURE

1. Remove the brake master cylinder cap.
2. Remove and discard the old filter.

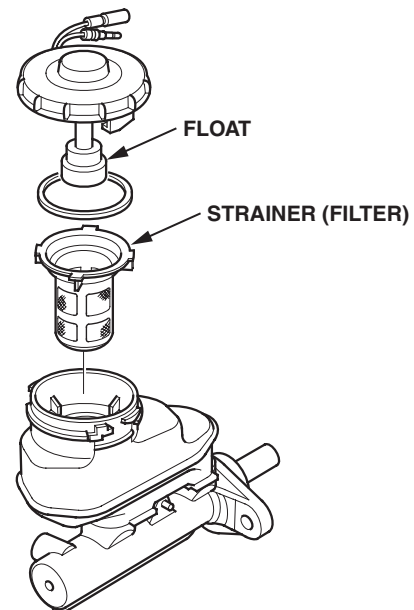

3. Install the new filter in the master cylinder.
4. Reinstall the brake master cylinder cap.
5. Check that the brake system indicator is off.