



## ABS Indicator Is On With DTCs 52, 53, 54, 61, or 81

### SYMPTOM

The ABS indicator is on with DTC 52 (motor stuck OFF), DTC 53 (motor stuck ON), DTC 54 (ABS fail-safe relay), DTC 61 (low IG1 voltage), or DTC 81 (CPU diagnosis and ROM/RAM diagnosis).

### PROBABLE CAUSE

Faulty ABS control unit.

### CORRECTIVE ACTION

Rather than troubleshooting any of these specific DTCs, replace the ABS control unit.

### PARTS INFORMATION

ABS Control Unit (includes motor connector):  
P/N 57010-S9A-000, H/C 7096704

### REQUIRED MATERIALS

Brake Fluid:  
P/N 08798-9008, H/C 4423802

### WARRANTY CLAIM INFORMATION

**In warranty:** The normal warranty applies.

Operation Number: 413113

Flat Rate Time: 1.5 hours

Failed Part: P/N 57110-S9A-003,  
H/C 6894059

Defect Code: 072

Contention Code: B03

### REPAIR PROCEDURE

1. Make sure you have the audio system anti-theft code. Record the radio station presets.
2. Disconnect the negative battery cable.
3. Remove the power steering reservoir tank.

4. Pull up the lock on the ABS control unit 47P connector, then disconnect the connector.

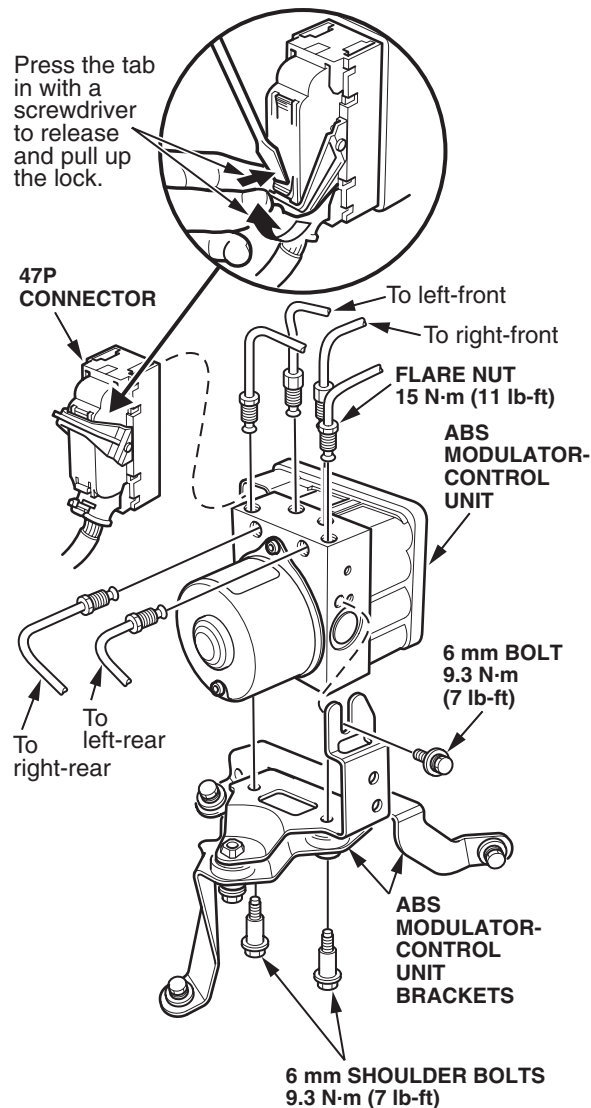

5. Disconnect the six brake lines.
6. Remove the two 6 mm shoulder bolts and the 6 mm bolt, then remove the ABS modulator-control unit from the bracket.

- Remove the two T25 Torx bolts from the motor cover, and remove the solenoid body. Discard the old ABS control unit.

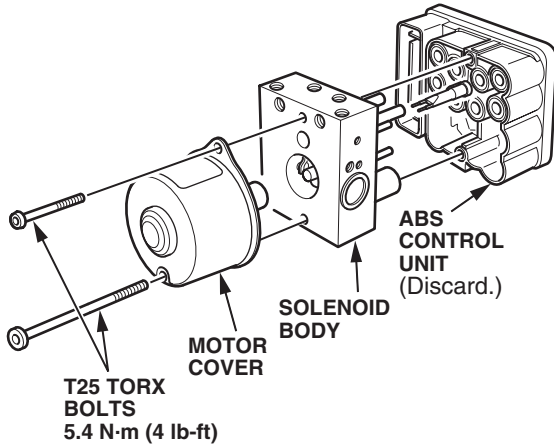

- Remove and discard the old motor connector. Insert the new motor connector into the new control unit. Make sure it is seated securely.

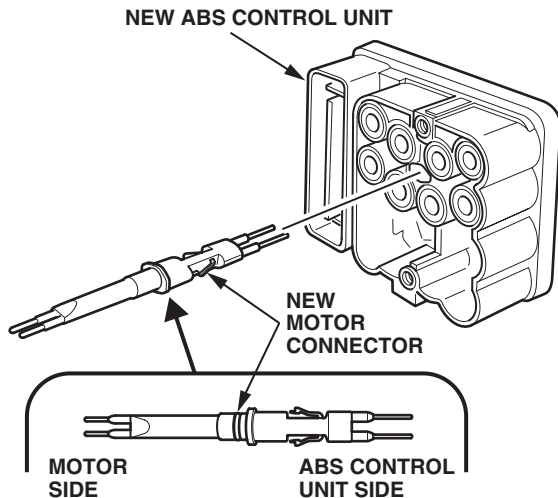

- Install the new ABS control unit onto the solenoid body with the motor connector going through the body.
- Install the motor onto the solenoid body. Make sure the motor connector pins are connected to the sockets on the motor.
- Reinstall the two T25 Torx bolts. Torque them to 5.4 N•m (4 lb-ft).
- Install the ABS modulator-control unit onto the bracket, and torque the two 6 mm shoulder bolts and the 6 mm bolt to 9.3 N•m (7 lb-ft).
- Align the connecting surface of the ABS control unit 47P connector, then connect and lock the connector.
- Connect the six brake lines. Torque them to 15 N•m (11 lb-ft).

- Bleed the brake system, starting with the front wheels (see the 2002 CR-V Shop Manual).
- Connect the negative battery cable.
- Start the engine, and check that the ABS indicator and brake system indicator go off.
- Reset the driver's window auto-up feature:
  - Make sure the driver's window is fully closed.
  - Push down and hold the window switch until the window is fully open.
  - Pull back and hold the window switch until the window is fully closed, then hold the switch for at least 2 more seconds.
- Do the idle learn procedure:
  - Make sure *all* electrical items (A/C, audio unit, defogger, lights, etc.) are turned off.
  - Let the engine warm up to its normal operating temperature (the cooling fan cycles twice).
  - Let the engine idle for 10 minutes, with the throttle fully closed and all electrical items turned off.
- Enter the audio system anti-theft code and station presets. Set the clock.
- Test-drive the vehicle, and check that the ABS indicator and brake system indicator do not come on.