



Applies To: **2001 Civic 2-Door – ALL**
2002 Civic 2-Door – See VEHICLES AFFECTED

July 2002

Rattle From the High Mount Brake Light

SYMPTOM

A rattle coming from the area of the high mount brake light when going over rough road surfaces.

PROBABLE CAUSE

The felt that is attached to the mounting hook on the package tray has been pushed out of position.

VEHICLES AFFECTED

2002 Civic 2-Door:

KK – From VIN 1HGEM2...2L50001
 thru 1HGEM2...2L500023

KE – From VIN 1HGEM2...2L60001
 thru 1HGEM2...2L601718

KG – From VIN 1HGEM2...2L60001
 thru 1HGEM2...2L601806

KX – From VIN 1HGEM2... 2L90001
 thru 1HGEM2...2L901143

CORRECTIVE ACTION

Install 10T EPT foam between the package tray and the parcel shelf at the high mount brake light.

REQUIRED MATERIALS

10T EPT Foam:
 P/N 06992-SA5-000, H/C 2086668
 (This amount will repair about 30 to 40 vehicles.)

WARRANTY CLAIM INFORMATION

In warranty: The normal warranty applies.

OP#	DESCRIPTION	FRT
714002	Diagnosis and install EPT foam	0.2
714092	Test-drive	0.3

Failed Part: P/N 84500-S5P-E01ZA
 Defect Code: 043
 Contention Code: B07

DIAGNOSIS

Have an assistant drive the vehicle over rough road surfaces. When you hear the rattle, apply pressure to the high mount brake light. If the rattle is eliminated, go to REPAIR PROCEDURE. If the rattle is still present, look for other causes.

REPAIR PROCEDURE

1. Cut two 38 x 38 mm pieces of 10T EPT foam.
2. Remove the backing and attach the two pieces of foam together, adhesive side to adhesive side.
3. Open the trunk.
4. Insert the foam between the package tray and the parcel shelf at the opening for the high mount brake light. Install the foam at the rear of the opening for the high mount brake light wiring. Push the foam into the rear of the opening toward the rear window.

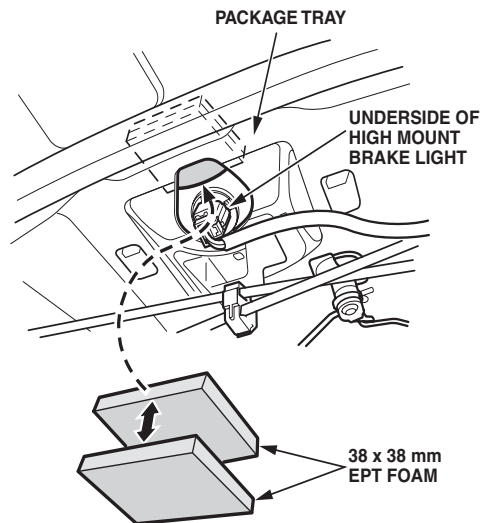

5. Drive the vehicle to confirm that the rattle from the high mount brake light has been eliminated. If the rattle has not been eliminated, recheck your positioning of the foam. If the foam is properly installed, look for other causes.