

Maintenance

Transmission Oil

NOTE: Check the oil at operating temperature, engine OFF, and the car on level ground.

1. Remove the oil filler plug, then check the level and condition of the oil.

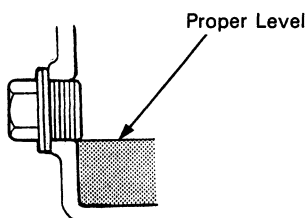

2. The oil level must be up to the filler hole. If it is below the hole, add oil until it runs out, then reinstall the oil filler plug.
3. If the oil is dirty, remove drain plug and drain transmission.
4. Reinstall the drain plug with a new washer, and refill to proper level.

NOTE: The drain plug washer should be replaced at every oil change.

5. Reinstall the oil filler plug with a new washer.

Oil Capacity

1.8 l (1.9 U.S. qt.) after drain.

1.9 l (2.0 U.S. qt.) after overhaul.

Use only SAE 10W-30 or 10W-40, SF or SG grade.

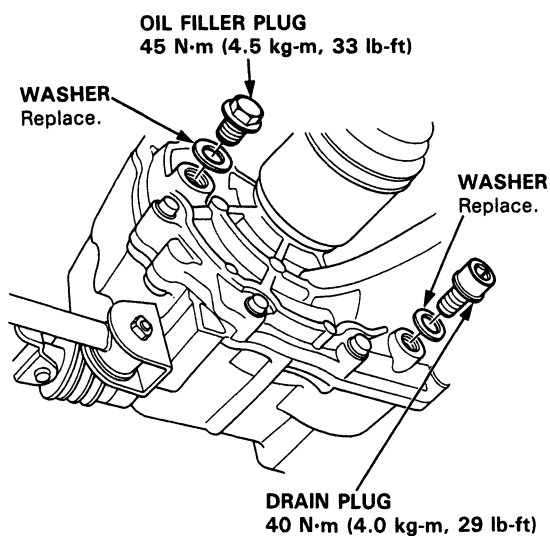

Back-up Light Switch

Replacement

NOTE: To check the switch, see section 23.

1. Disconnect the connector, then remove the switch connector from the connector clamp.
2. Remove the switch.
3. Install the new washer and switch.

